

CREDITS

Document Author: **Brett “5thumbs” Miller**, five.thumbs@yahoo.com *Notable Technical Contributor:* **Muhammad “miqbal” Iqbal**, iqbal.tiro@gmail.com

Special thanks to the following who helped make this document possible:

- 1) [Aron Nelson](#) and everyone else on the diystompboxes.com forum.
- 2) [Johan](#) and everyone else on the freestompboxes.org forum.
- 3) [Robert Keeley](#) for making information on his DS-1 “Seeing Eye” and “Ultra” mods available to the public.
- 4) [Jack Orman](#) for his [“More Saturation Controls”](#) article, his [DS-1 Q2 gain mod](#), along with all the information he’s shared with the DIY pedal community.
- 5) [Mark Hammer](#) for his assistance with the [‘True-Bypass DS-1 Distortion’ circuit](#), plus all the experience and guidance he’s shared with us DIYers.
- 6) [R.G. Keen](#) for generously sharing his vast knowledge and patience with us all.
- 7) The folks at Bossarea.com for information assisting in identifying power components in the pre-1994 DS-1 pedals.
- 8) Mxrmxr and Christ Briere (cbriere) at freestompboxes.org for [schematic information](#) for the [Tonebone Classic™](#) and [JMP-1™ preamp](#).

DISCLAIMER

The information in this document is accurate to the best of the authors’ knowledge. While we’ve done our best to get all the details correct, there are no warranties or guarantees express or implied regarding its accuracy. This information is provided for reference purposes only, which essentially means that if you blow up your DS-1 while modifying it, burn yourself on a soldering iron while trying to build a pedal based upon these instructions or fall victim to some other misfortune after reading this information... it’s your fault, not ours.

If you are having problems with your DS-1 mod or DS-1 replica build, please visit the diystompboxes.com forum and use the Search feature to see if the problem you’re experiencing has been previously solved by others. If not, please read [this page](#) before posting for help in the forum. By doing this, you may solve the problem yourself before posting...and if not, you’ll be communicating in a manner that will allow the other members of the forum to help you more readily.

All trademarks remain the property of their respective owners. (Tonebone Classic™ is a trademarked product of Radial Engineering™. JMP-1™ is a trademarked product of Marshall Amplification plc. BOSS® is a registered trademark of the Roland Corporation.) None of the information represented in this document is affiliated with or endorsed by these entities.

CONTENTS

1. [Introduction](#)
2. [Build a Stock DS-1 Distortion](#)
3. [Build a True-Bypass DS-1 Distortion](#)
4. [Robert Keeley DS-1 “Seeing Eye” / “Ultra” Mods](#)
5. [Brett Miller DS-1 “MIJ” Mod](#)
6. [Brett Miller DS-1 “MIJ-Plus” Mod](#)
7. [Brett Miller DS-1 “Mondo-MIJ” Mod](#)
8. [Brett Miller DS-1 “PHLAT” Mod](#)
9. [Brett Miller DS-1 “Vintage Ripper” Mod](#)
10. [Brett Miller DS-1 “Huevos Grandes” Mod](#)
11. [Sound Clips](#)
12. [Appendix A: Where Can I Find B20K Pots?](#)
13. [Appendix B: How Do I Modify My Post-1994 DS-1 To Match The Original DS-1?](#)

INTRODUCTION

Have you ever wanted to build your own DS-1 Distortion, but could only find work-a-likes, schematics for the pre-1994 “vintage” DS-1 or just plain inaccurate schematics on the Internet? If so, then this document is for you. We’ll give you the information you need to build a version of the DS-1 distortion that matches the exact circuit used by the large Japanese manufacturer of the original post-1994 DS-1 Distortion (with the exception of replacing the SIP-8 dual op amp layout with a DIP-8 dual op amp layout.)

Please be advised that both of the DS-1 layouts in this document are a bit more complicated than your average beginner-level project. Please consider the following factors and honestly assess your skill-level before you begin building this project:

1. The component count is higher than a booster/overdrive/simple distortion (like the MXR Distortion+), which means more places to have to troubleshoot in the event of a failure.
2. The component spacing is rather tight on both layouts, so you will need to solder with care to avoid creating short-circuits via solder bridges.
3. If you attempt to build the “Stock DS-1 Distortion”, you will be working with JFETs in the flip-flop switching circuitry. Multiple JFETs often need to be tested and grouped to get a set of individual JFETs that will work as desired in the circuit. The topic of JFET matching is beyond the scope of this document, but if you wish to learn more about this topic, please read more about it over at [GEOFEX](#).

Given these factors, I’d rate the difficulty of this project as INTERMEDIATE. This means it is probably not a good idea for your first pedal build, but it will not be overly-difficult if you take your time and carefully assemble the pedal with the knowledge and skills you’ve developed in your previous pedal building experience.

BUILD A STOCK DS-1 DISTORTION

This schematic was reverse-engineered by Muhammad Iqbal from images of actual DS-1 circuit boards. All components in the schematic below are labeled with the same labels as the commercially-produced product, so if you find new DS-1 mods on the Internet that reference component numbers on the commercially-produced DS-1, they will be applicable to this circuit as well. This schematic includes all of the components from the original DS-1 board, including input and output buffers, as well as the switching circuitry.

This layout has been built and verified as successful by Muhammad Iqbal.

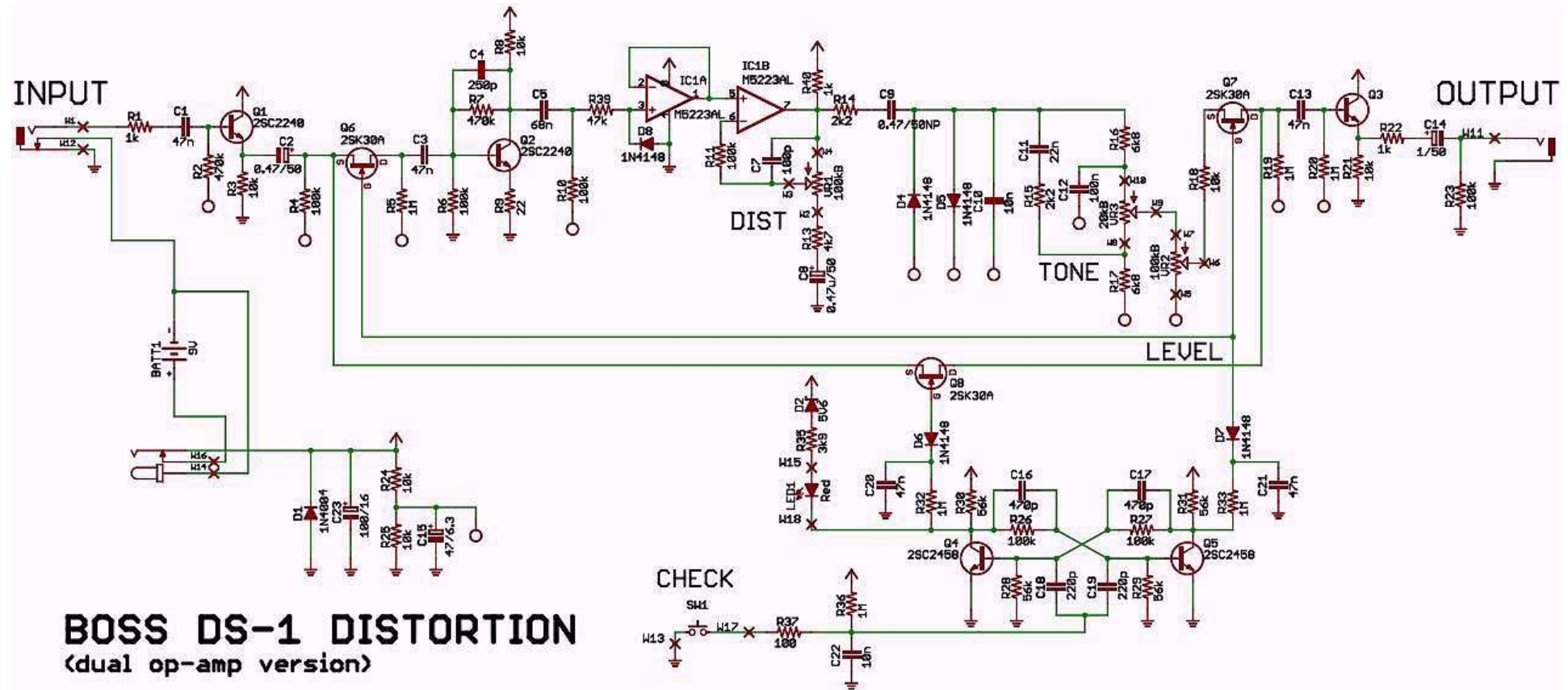

BOSS DS-1 DISTORTION (dual op-amp version)

Drawn: 01/2008

Thanks to Brett Miller<5thumbs> for his information on some component values.
Copyright 2008 Muhammad Iqbal/iqbal.tiro@gmail.com

The layout below is designed to fit into a BOSS[®]-style pedal enclosure, but may also be fit into a 1790-style enclosure.

Component Layout (enlarged):

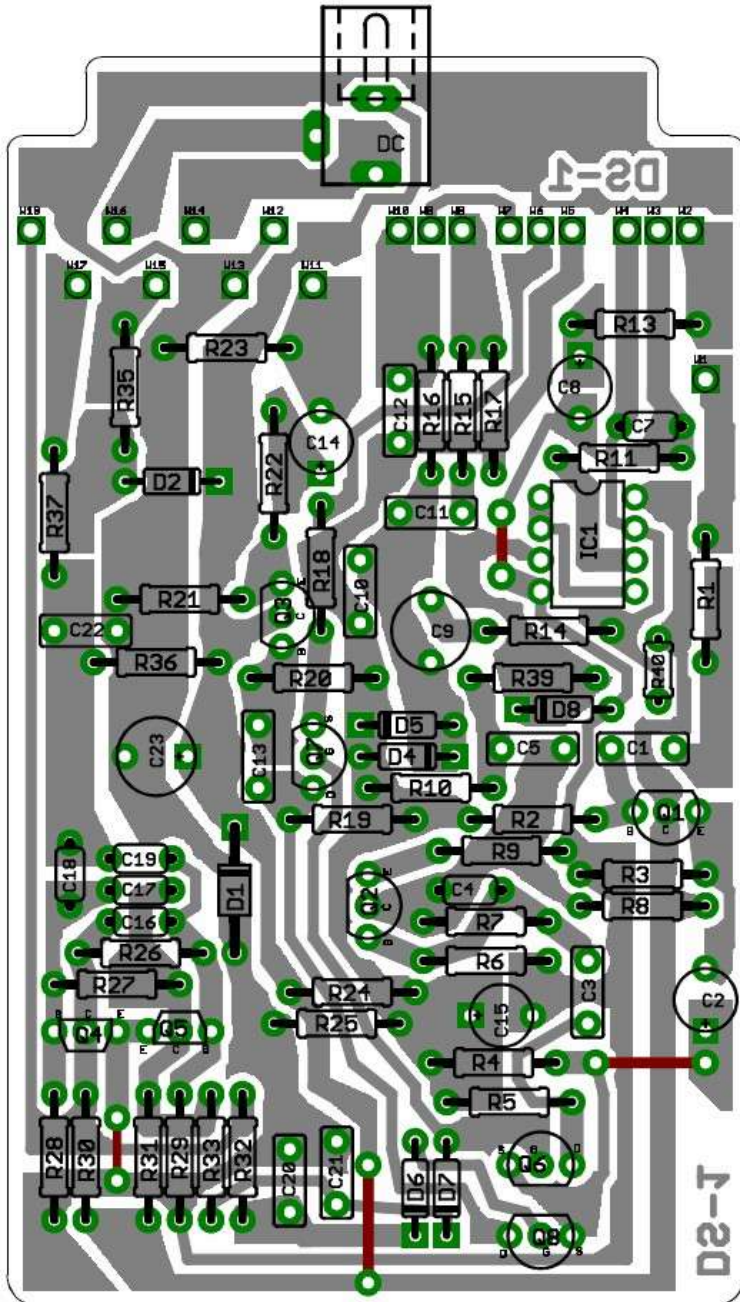

Ready-To-Transfer:



Stock DS-1 Layouts by: Muhammad Iqbal

Stock DS-1 Connections:

W1	– Input	W13	– Effect Switch, SPST Momentary
W2, W3, W4 (VR1)	– DIST Control, 100K Ω Linear Potentiometer	W14	– Board to Input Jack Ring, then Battery Negative (-)
W5, W6, W7 (VR2)	– LEVEL Control, 100K Ω Linear Potentiometer	W15	– +9V to LED (+)
W8, W9, W10 (VR3)	– TONE Control, 20K Ω Linear Potentiometer	W16	– Battery Positive (+)
W11	– Output	W17	– Effect Switch, SPST Momentary
W12	– Ground to Input Sleeve	W18	– Power return from LED Negative (-) to flip-flop switching circuit

Stock DS-1 Parts List:

C1 – 0.047 μ F	R1 – 1K Ω	R25 – 10K Ω	Q1 – 2SC2240*	*2N5088 transistors may be used in place of 2SC2240 transistors. You will need to orient the pins differently, as the 2SC2240 are B-C-E and 2N5088 are C-B-E.
C2 – 0.47 μ F/50V	R2 – 470K Ω	R26 – 100K Ω	Q2 – 2SC2240	
C3 – 0.047 μ F	R3 – 10K Ω	R27 – 100K Ω	Q3 – 2SC2240	
C4 – 250pF	R4 – 100K Ω	R28 – 56K Ω	Q4 – 2SC2458**	
C5 – 0.068 μ F	R5 – 1M Ω	R29 – 56K Ω	Q5 – 2SC2458	** BC549 or BC559 transistors may be used in place of 2SC2458 transistors. You will need to orient the pins differently, as the 2SC2458 are B-C-E and BC549/BC559 are C-B-E.
C6 – <i>omitted in original</i>	R6 – 100K Ω	R30 – 56K Ω	Q6 – 2SK30A***	
C7 – 100pF	R7 – 470K Ω	R31 – 56K Ω	Q7 – 2SK30A	
C8 – 1 μ F/50V	R8 – 10K Ω	R32 – 1M Ω	Q8 – 2SK30A	
C9 – 0.47 μ F/50V NP	R9 – 22 Ω	R33 – 1M Ω	LED1 – 3mm Red LED	
C10 – 0.01 μ F	R10 – 100K Ω	R34 – <i>omitted in original</i>	SW1 – SPST momentary	
C11 – 0.022 μ F	R11 – 100K Ω	R35 – 3K9 Ω	VR1 – 100K Ω Linear Pot	
C12 – 0.1 μ F	R12 – <i>omitted in original</i>	R36 – 1M Ω	VR2 – 100K Ω Linear Pot	
C13 – 0.047 μ F	R13 – 4K7 Ω	R37 – 100 Ω	VR3 – 20K Ω Linear Pot	
C14 – 1 μ F/50V	R14 – 2K2 Ω	R38 – <i>omitted in original</i>		
C15 – 47 μ F/6.3V	R15 – 2K2 Ω	R39 – 47K Ω		
C16 – 470pF	R16 – 6K8 Ω	R40 – 1K Ω	IC1 – NJM3404AD	***2N5457 transistors are somewhat close to 2SK30A transistors. You will need to orient the pins differently, as the 2SK30A are S-G-D and 2N5457 are G-S-D. If you want to purchase 2SK30A transistors, Small Bear Electronics has them.
C17 – 470pF	R17 – 6K8 Ω	D1 – 1N4004	<u>NOTE:</u>	
C18 – 220pF	R18 – 10K Ω	D2 – 5.6V Zener	The NJM3404AL SIP8 dual op amp is currently used in post-1994 DS-1 pedals. This chip is available in DIP-8 format, but the older M5223AL and BA728N dual op amps are not.	
C19 – 220pF	R19 – 1M Ω	D3 – <i>omitted in original</i>	If you're going for a stock DS-1, try the NJM3404AD (DIP-8) in this layout.	
C20 – 0.047 μ F	R20 – 1M Ω	D4 – 1N4148		
C21 – 0.047 μ F	R21 – 10K Ω	D5 – 1N4148		
C22 – 0.01 μ F	R22 – 1K Ω	D6 – 1N4148		
C23 – 100 μ F/16V	R23 – 100K Ω	D7 – 1N4148		
	R24 – 10K Ω	D8 – 1N4148		

Stock DS-1 Wiring:

The diagram below is a 1:1 scale image of an installation of the Stock DS-1 in a 1790-style enclosure.

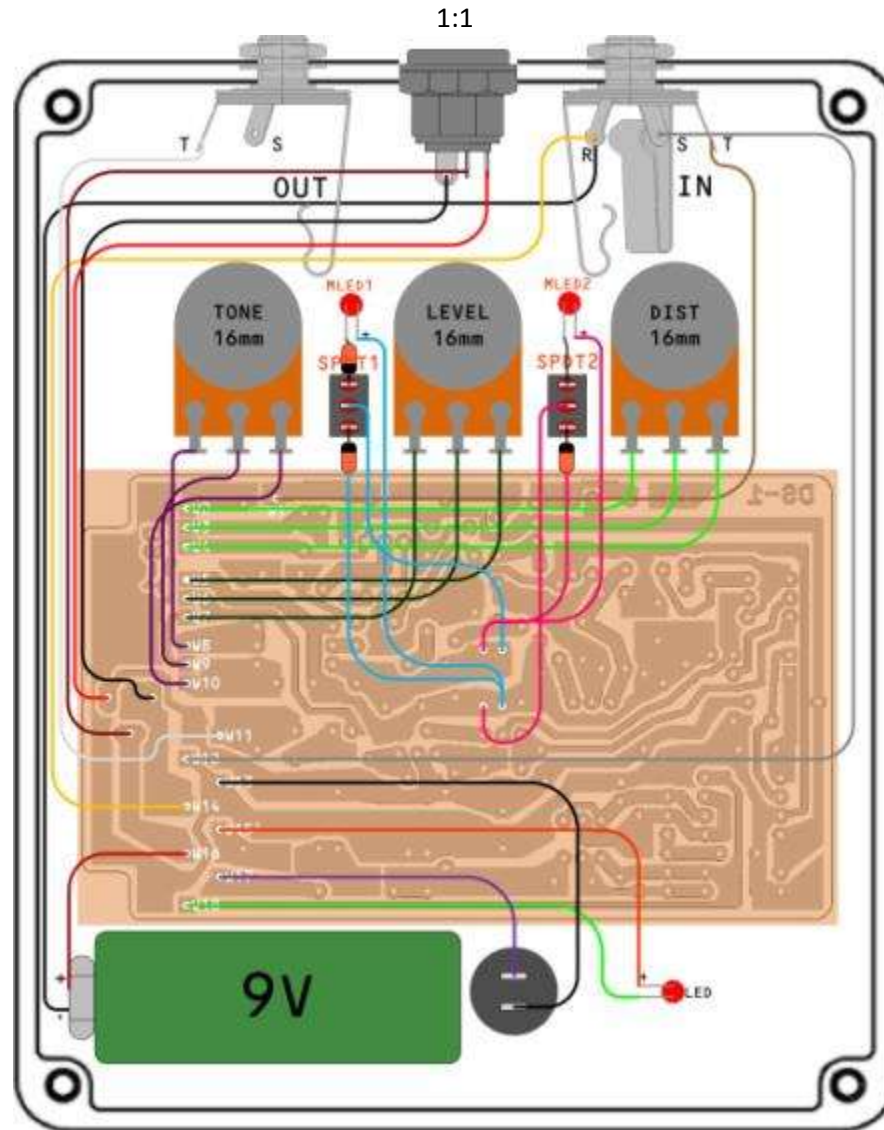

Stock DS-1 Enclosure Drilling Template:

Print out this page, cut out the diagram below and place it on top of your 1790-style enclosure, folding the smaller rounded rectangle over the edge and tape everything down securely. All holes are sized according to manufacturer specifications. Since there are variances between hole sizes required by different manufacturers, you may need to reduce/enlarge some of the holes to fit your components. It is a good practice to purchase a dial caliper and measure the exact parts you plan to use before drilling any enclosure, but this template should work for most components available.

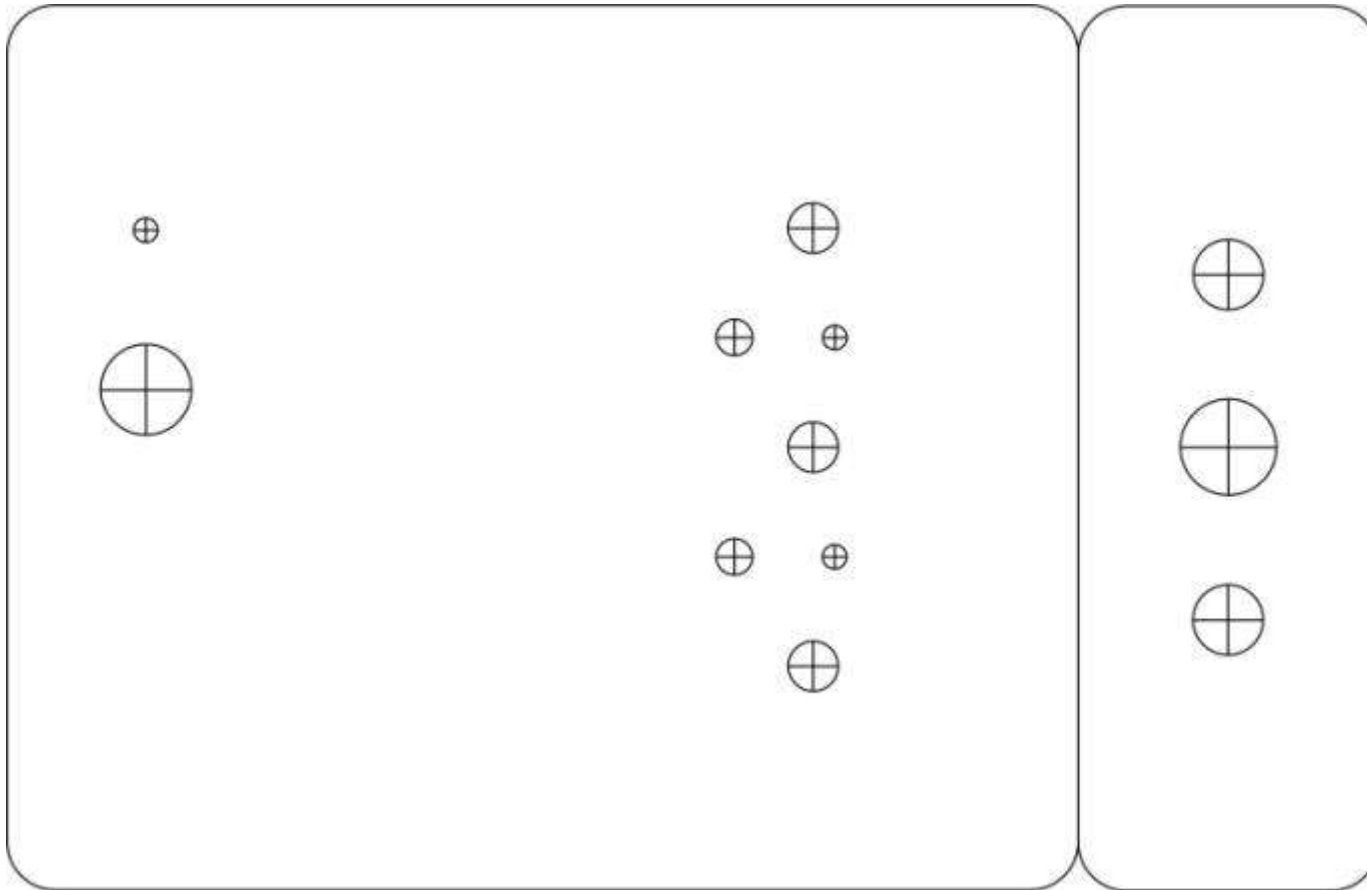

BUILD A TRUE-BYPASS DS-1 DISTORTION

This schematic was developed by Brett Miller from Muhammad Iqbal's "[BOSS® DS-1 Distortion](#)" schematic. All components in the schematic below are labeled with the same labels as the commercially-produced product, so if you find new DS-1 mods on the Internet that reference component numbers on the commercially-produced DS-1, they will be applicable to this circuit as well. This schematic *does not include* all of the components from the original DS-1 board, as it removes the input/output buffers and the switching circuitry.

This schematic also includes Robert Keeley's "Seeing Eye" and "Ultra" mods, which are described in-depth in the "[Robert Keeley DS-1 "Seeing Eye" / "Ultra" Mods](#)" section at the end of this document. Please note that circuit components that map to the original DS-1 circuit have red lines, whereas the Keeley mods have orange lines. You can build this design with or without the Keeley mods, but if you do not include the mods, please be sure to install jumpers between the pads marked 'COM' and '1' on the SPDT1 and SPDT2, as indicated on the Component Layout. I would recommend installing the Keeley mods, as I have designed it to allow switching between either Keeley diode mod individually, or you can switch the clipping diode mods off altogether and have a nearly-stock DS-1 sound.

This layout is unverified at this time, as I've got five DS-1 pedals of various vintages and mods...and I really don't want one more. If you build this successfully, please let me know and I'll credit you as the initial build verifier in this doc.

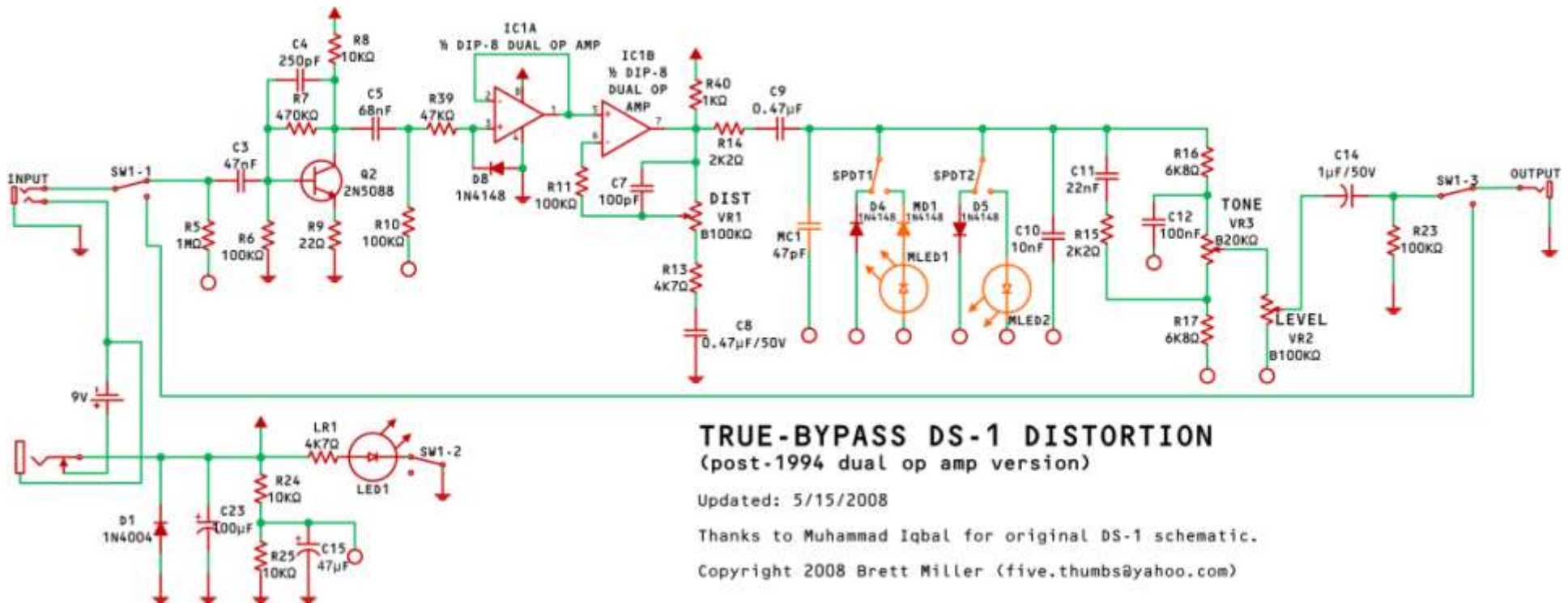

The layout below is designed to fit into a Hammond 1590BB-style enclosure.

Component
Layout
(enlarged):

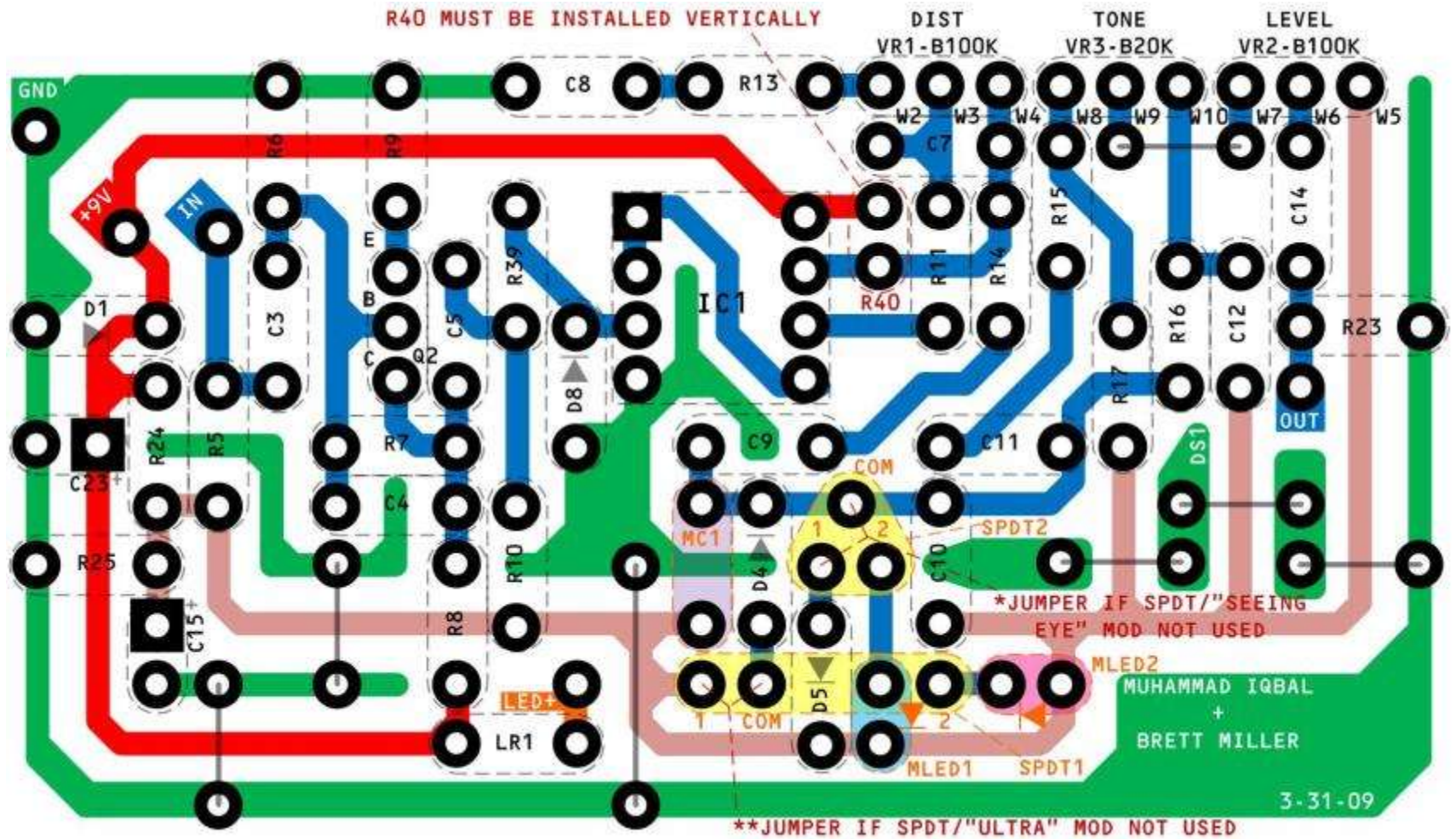

Ready-To-
Transfer:

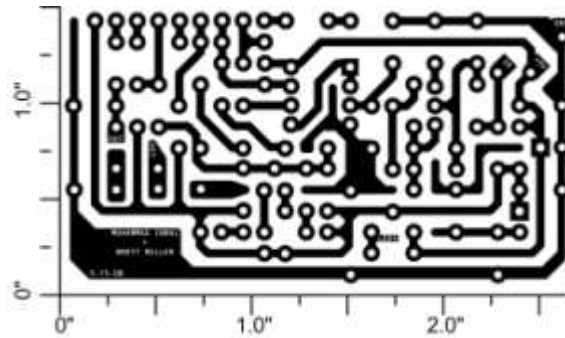

True-Bypass DS-1 Layouts by: Brett Miller

True-Bypass DS-1 Connections:

IN	– Input	OUT	– Output
W2, W3, W4 (VR1)	– DIST Control, 100K Ω Linear Potentiometer	GND	– Ground
W5, W6, W7 (VR2)	– LEVEL Control, 100K Ω Linear Potentiometer	+9V	– +9V Input
W8, W9, W10 (VR3)	– TONE Control, 20K Ω Linear Potentiometer	LED+	– Current-limited + 9V power to status LED (LED1)

True-Bypass DS-1 Parts List:

C3 – 47nF	R5 – 1M Ω	D1 – 1N4004	Q2 – 2N5088*	*2SC2240 transistors may be used in place of 2N5088 transistors. I have designed this layout around the 2N5088, so if you want to use 2SC2240 as in the original, you will need to orient the pins differently, as the 2SC2240 are B-C-E and 2N5088 are C-B-E.
C4 – 250pF	R6 – 100K Ω	D4 – 1N4148		
C5 – 68nF	R7 – 470K Ω	D5 – 1N4148	VR1 – 100K Ω Linear Pot	
C7 – 100pF	R8 – 10K Ω	D8 – 1N4148	VR2 – 100K Ω Linear Pot	
C8 – 0.47 μ F	R9 – 22 Ω		VR3 – 20K Ω Linear Pot	
C9 – 0.47 μ F	R10 – 100K Ω	LED1 – 3mm Red LED		
C10 – 10nF	R11 – 100K Ω		IC1 – NJM3404AD	
C11 – 22nF	R13 – 4K7 Ω	MD1 – 1N4148		
C12 – 100nF	R14 – 2K2 Ω	MLED1 – 3mm Red LED	<u>NOTE:</u>	
C14 – 1 μ F/50V	R15 – 2K2 Ω	MLED2 – 3mm Red LED	The NJM3404AL SIP8 dual op amp is currently used in post-	
C15 – 47 μ F/6.3V	R16 – 6K8 Ω		1994 DS-1 pedals. This chip is available in DIP-8 format, but	
C16 – 470pF	R17 – 6K8 Ω	SW1 – 3PDT latching	the older M5223AL and BA728N dual op amps are not. If you're going for a stock DS-1, try the NJM3404AD (DIP-8) in this layout.	
C23 – 100 μ F/16V	R18 – <i>omitted in TB layout</i>	SPDT1 – SPDT toggle, ON-ON		
	R23 – 100K Ω	SPDT2 – SPDT toggle, ON-ON		
MC1 – 47pF	R24 – 10K Ω			
	R25 – 10K Ω			
	R39 – 47K Ω			
	R40 – 1K Ω			
	LR1 – 4K7 Ω			

True-Bypass DS-1 Wiring:

The diagram below is a 1:1 scale image of an installation of the True-Bypass DS-1 in a Hammond 1590BB-style enclosure.

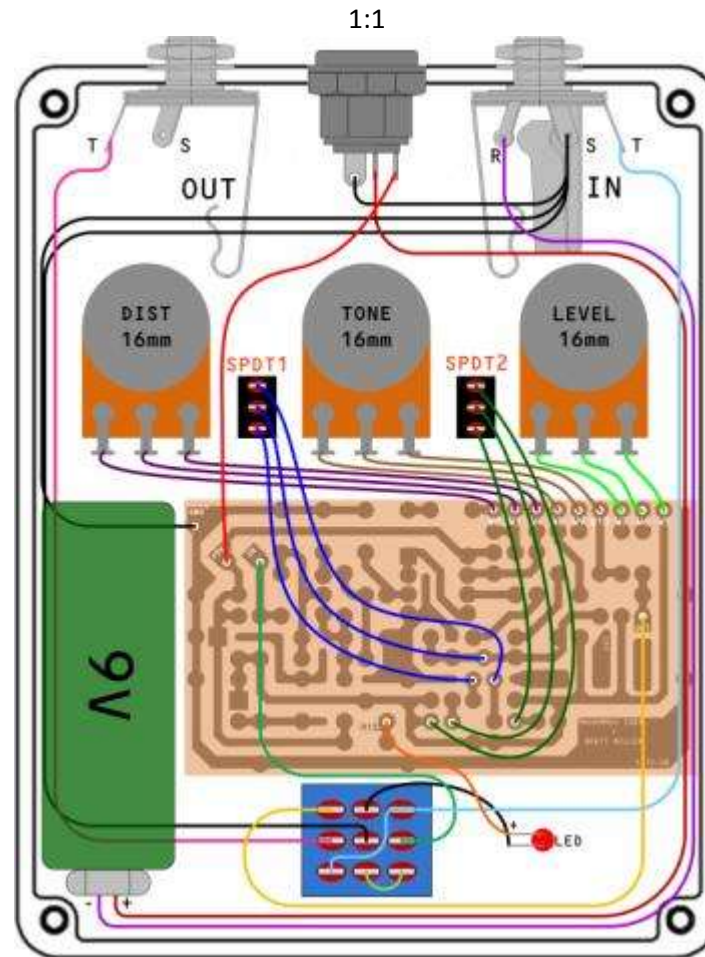

True-Bypass DS-1 Enclosure Drilling Template:

Print out this page, cut out the diagram below and place it on top of your Hammond 1590BB enclosure, folding the smaller rounded rectangle over the edge and tape everything down securely. All holes are sized according to manufacturer specifications. Since there are variances between hole sizes required by different manufacturers, you may need to reduce/enlarge some of the holes to fit your components. It is a good practice to purchase a dial caliper and measure the exact parts you plan to use before drilling any enclosure, but this template should work for most components available.

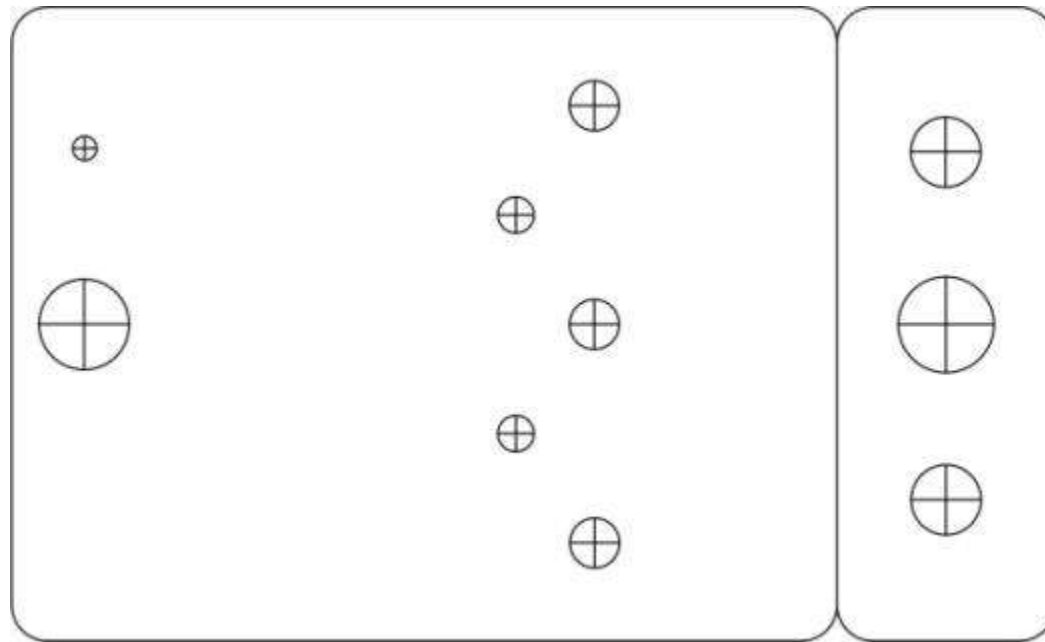

Robert Keeley has public information on his site about his DS-1 "Seeing Eye" and "Ultra" mods here: <http://www.robertkeeley.com/audio616/dstech.html>, which is why his mod information is included in this document.

There are other modifications you can make to your DS-1 that are too numerous to list here. Please visit the [diystompboxes.com forum](http://diystompboxes.com) and search for "DS-1 mods" to find more mods for your DS-1.

Robert Keeley's DS-1 "Seeing Eye" / "Ultra" Mod:

- 1) Replace C1, C3, C5, C12 and C13 with 0.1 μ F metal film capacitors.
- 2) Replace C2, C8, C9 and C14 with 1 μ F metal film capacitors.
- 3) Replace C11 with 0.047 μ F metal film capacitor.
- 4) Replace C7 with a 220pF silver mica capacitor.
- 5) Replace R13 with a 2.4K Ω metal film resistor.
- 6) Replace R39 with a 20K Ω metal film resistor.
- 7) Replace R14 with a 1.5K Ω metal film resistor.
- 8) Add a 47pF silver mica capacitor in parallel to the D4/D5 clipping diodes (as illustrated below.)



This mod is soldered on the trace-side of the board, not on the component-side.

NOTE: On the "True-Bypass DS-1 Distortion" build instructions above, you do not need to solder the 47pF cap across the D4/D5 diodes as illustrated immediately above, as I have added holes/pads to the left of D4/D5 for you to add this cap as part of the "Ultra" mod.

9) "ULTRA" Diode Mod:

Add a 3mm red LED in series with D4. To make this mod switchable so you can choose to have the LED/D4 diode combination or just the D4 diode, you can wire an On-On SPDT toggle switch as follows:

You will need one additional 1N4148 (or other diode matching the one in D4) to construct this mod as illustrated below.



NOTE: On the "True-Bypass DS-1 Distortion" build instructions above, you do not need to remove D4 and off-board wire the switch with diodes/LED as illustrated immediately above, as I have added holes/pads near D4/D5 for you to add the SPDT switch and LED as part of the "Ultra" mod.

10) "Seeing Eye" Diode Mod:

Replace D5 with a 3mm red LED. To make this mod switchable so you can choose to have the LED or just the D5 diode, you can wire an On-On SPDT toggle switch as follows:

You may use the original D5 diode as illustrated below.

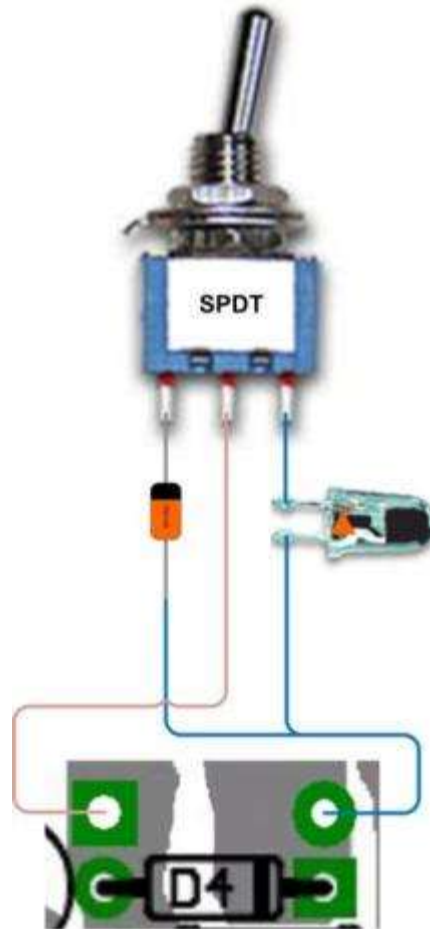

NOTE: On the "True-Bypass DS-1 Distortion" build instructions above, you do not need to remove D5 and off-board wire the switch with diode/LED as illustrated immediately above, as I have added holes/pads near D4/D5 for you to add the SPDT switch and LED as part of the "Seeing Eye" mod.

In [Appendix B](#), I describe the major differences between the vintage, pre-1994 DS-1 and the post-1994 pedal. If you would like to understand why the components in the MIJ-Mod were selected and changed to the values below, please read that section.

The intent of this mod is to alter the post-1994 DS-1 to make it sound like the vintage DS-1. I've tested a stock DS-1 modified with the MIJ-Mod side-by-side with a genuine pre-1994, MIJ DS-1 and found the similarity in sound characteristics to be remarkable.

Mod Steps:

1. Change C7 from 100pF ceramic disc capacitor to a 250pF ceramic disc capacitor.
2. Change C8 from 0.47µF/50V aluminum electrolytic capacitor to 1µF/50V aluminum electrolytic capacitor; save the 0.47µF/50V cap for the next step.
3. Remove the 0.068µF film capacitor from C5 and replace it with the 0.47µF/50V aluminum electrolytic capacitor previously removed from C8 in Step 2.

NOTE: Tantalum capacitors are not recommended for C5 and C8. BOSS[®] used aluminum electrolytic capacitors in these positions originally, so since we're trying to recapture the sound of the pre-1994 DS-1, I used aluminum electrolytic caps in these positions as well. Despite their somewhat bad reputation, aluminum electrolytic caps sound pretty good in these positions. I tried tantalum caps in these positions and they made the distortion sound trebly and harsh. Tantalum caps can be used in some locations in the DS-1 with positive effect (like [Monte Allums](#) does in [his DS-1 mods](#)), but they do not sound good in this mod.

Metal film caps may be used in C5 and C8, but please bear in mind that BOSS didn't use film caps for C5 and C8 in the original, so you'll be making a hybrid-of-a-hybrid and might not sound as true to the pre-1994 DS-1 sound as I have tried to achieve in this mod. I did try film caps in C5 and C8 and they did sound good, but not as close to the original as the aluminum electrolytic caps.

The same goes for using a silver mica cap in C7. Try it if you want to, but BOSS used ceramic caps in C7 in both pre-1994 and post-1994, which is why they are used in this mod.

I would strongly advise you to try this mod without mixing in any other mods first. A post-1994 DS-1 with the MIJ-Mod has a sound that is less-compressed sounding than the stock post-1994 DS-1. The note articulation is vastly improved as well. You can crank the DIST control with this mod and it still sounds good, unlike the post-1994, where cranking the DIST control results in a bit of a fuzzy mess (in my opinion, of course.)

If you are fortunate enough to own both a vintage DS-1 and a post-1994 DS-1 modified with the MIJ-Mod, if you carefully listen to them side-by-side, you'll notice that the vintage pedal has slightly less bass and sounds slightly more compressed than the post-1994 DS-1 with the MIJ-Mod. Personally, I like the post-1994 with the MIJ-Mod best, as it has almost identical tone characteristics to the vintage DS-1, but has a less-compressed, higher-fidelity sound that compares favorably with some of the best DS-1 mods out there. (And yes, I am biased. ☺) But don't take my word for it, let your ears be your guide to which one is best for you.

After developing the MIJ-Mod, it has become my favorite DS-1 pedal. Unfortunately, I found that, with the increased fidelity of the M5223AL and NJM3404AL chips over the TA7136P chip, the distortion was a little bit fizzy with the DIST knob cranked for maximum gain. Gain is good, fizz is bad (at least with how I commonly use the DS-1), so I wanted to smooth out the distortion a bit further. So in essence, the “MIJ-Mod PLUS” is the MIJ-Mod with additional changes to diodes D4/D5 to smooth out the distortion.

I started by focusing on the clipping diodes. Many folks like switching to LEDs for the clipping diodes, but I prefer a more saturated sound than LEDs provide. I wanted to raise the clipping threshold from the 1N4148/1N914 levels in the stock DS-1, which led me to examine the following clipping thresholds for common devices used in the clipping circuits of overdrive/distortion pedals:

- LEDs ~1000-1200mV (and higher for some of the super-bright varieties)
- 1N34A Germanium diodes ~300-350mV
- 1N4002 silicon power diodes ~450-500mV
- 1N914/1N4148 silicon diodes ~550-600mV
- NPN silicon transistors (Base->Emitter –or– Base->Collector) ~650-700mV.

In the past, I’ve typically preferred asymmetrical over symmetrical clipping, so I wanted to replace D4 and D5 with components that clip at different levels. I didn’t want to go as high as LEDs (1000-1200mV) and I didn’t want the fuzzy saturation/volume-loss from going as low as 300-350mV with Germanium diodes. I wanted to have one side clip between 800 and 900mV and the other side clip between 600 and 700mV, so I ended up using a 1N4002 diode and 1N34A diode in series to replace D4 and a 2N3895A silicon transistor (Base->Emitter, with the Collector pin removed) in D5. This resulted in a less fizzy distortion that was more pleasing to my ear and, in fact, another baby-step closer to the sound of the vintage DS-1. My gut feeling as to why the post-1994 DS-1 with the MIJ-Mod sounds slightly fizzier at full DIST is due to the increased fidelity of the M5223AL and NJM3404AL dual op amps. The slightly-decreased fidelity of the TA7136P seems to mask this fizz better, whereas the M5223AL and NJM3404AL allow this fizz to be heard a little bit more clearly.

When installing the diodes in D4, make sure you’ve got the components oriented correctly. On the 1N4002/1N34A pair, make sure the lines on the diodes are both facing the same direction, as pictured below on the left. I used a 2N3859A NPN transistor in D5 because the Base and Emitter are the outside pins, as pictured below on the right. You can use any common NPN silicon transistor that has a forward voltage of 650mV-700mV between Base->Emitter or Base->Collector (verified via diode test on a digital multi-meter), but make sure to read the datasheet so you can locate the Base/Emitter or Base/Collector pins correctly. With the NPN silicon transistors, remember that the current flows from the Base to either the Emitter or Collector, so the “diode arrow” printed on the board should always point towards the Emitter or Collector and away from the Base.

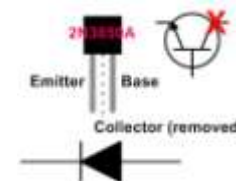
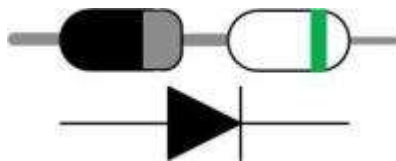

OK, now that we’re at the third of the “MIJ”-type mods, let’s recap a little. The original “MIJ” mod was designed to replace only the minimal number of components necessary to make the post-1994 DS-1 sound like the pre-1994 MIJ vintage DS-1. The “MIJ-Plus” mod was designed to remove some of the “fizz” from the “MIJ” mod by increasing the proximity to clip in the D4/D5 clipping diodes. The “Mondo-MIJ” mod is designed to bring a higher fidelity sound to the “MIJ”-type mods through the use of film capacitors, an upgraded op amp and a more sophisticated clipping circuit.

Admittedly, this mod is the most complex of the “MIJ”-type mod series. To extend the mod much further than the “Mondo-MIJ” would result in labor hours and mod part expenditures becoming a bit ludicrous; at that point, building a ground-up pedal would be easier and possibly cheaper. Having said all that, let’s get on with the “Mondo-MIJ” details.

I’ve broken the “Mondo-MIJ” mod instructions into three parts. You could apply any of these sections to a DS-1 separately, but to complete the “Mondo-MIJ”, you really need to apply all three parts to your post-1994 DS-1. These instructions do not require you to perform any other mods previously to complete the “Mondo-MIJ.” These instructions assume you are starting with a stock post-1994 DS-1.

“Mondo-MIJ” Part 1:

1. Replace C1 with a 0.1 μ F metal film capacitor.
2. Replace C2 with a 0.47 μ F metal film capacitor.
3. Replace C5 with a 0.47 μ F metal film capacitor.
4. Replace C7 with a 250pF ceramic disc capacitor.
5. Replace C8 with a 1 μ F metal film capacitor.
6. Replace C9 with a 0.47 μ F metal film capacitor.
7. Replace C13 with a 0.1 μ F metal film capacitor.
8. Replace C14 with a 1 μ F metal film capacitor.
9. Replace R13 with a 2.4K Ω metal film resistor.

“Mondo-MIJ” Part 2:

The M5223AL and NJM3404AL dual op amps sounds pretty good in the DS-1 circuit, but it can also sound a bit harsh at times, depending upon your guitar and/or the level of DIST control. To smooth out the distortion, I chose to replace the M5223AL and NJM3404AL in-line dual op amps with a Burr Brown OPA2134PA dual op amp.

The OPA2134PA is a DIP8 package, so you will need to either purchase a SIP8 to DIP8 adapter board or make one yourself. If you wish to buy one, you can buy them from Cimarron Technology: <http://cimarrontechnology.com/index.asp?PageAction=VIEWPROD&ProdID=34>. If you wish to etch and drill your own adapter board, you can use the ready-to-transfer image below.

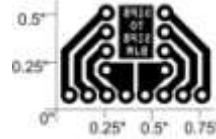

The vertically-aligned holes are for the DIP8 op amp, with Pin 1 being at the upper-left. It is recommended that you install a DIP8 socket in this position. The horizontally-aligned holes are for the pin connectors. You can use 22-gauge tinned bus wire to make these pins by soldering the wire into the hole, bending the wire 90-degrees and clipping to desired length. NOTE: You should install the OPA2134PA op amp *after* you’ve soldered the DIP8 socket and pins; this will reduce the heat the op amp IC is exposed to.

Once you’ve got your SIP8 to DIP8 adapter board, de-solder the M5223AL or NJM3404AL op amp and remove it. Install [Mill-Max in-line sockets](#) in place of the removed M5223AL or NJM3404AL. Install the OPA2134PA into the DIP8 socket, then install the entire adapter assembly into the in-line sockets on the main PCB. NOTE: You may need to gently bend the pins on the adapter board one direction or the other to get the necessary clearance to fit everything back into the case.

“Mondo-MIJ” Part 3:

This part of the “Mondo-MIJ” mod is perhaps the most complicated, yet also potentially the most unique. The inspiration for this part of the “Mondo-MIJ” mod came from [an article by Jack Orman](#) where he described alternative distortion saturation and blending configurations.

This part of the mod replaces the hard clipping diodes in D4 and D5 with a network of diodes that are blended together to create a mixed distortion sound.

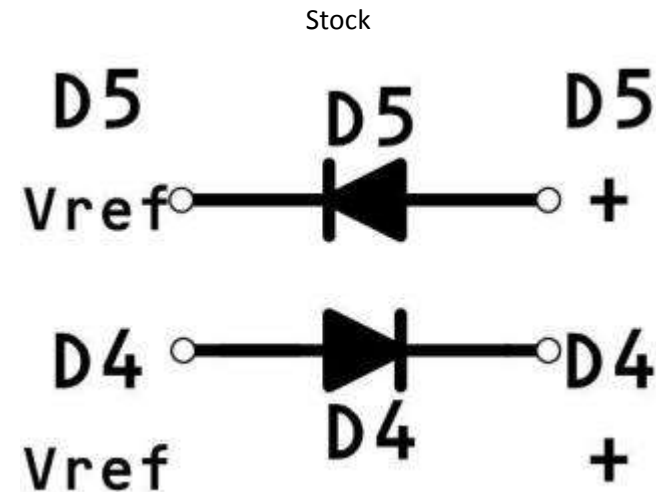
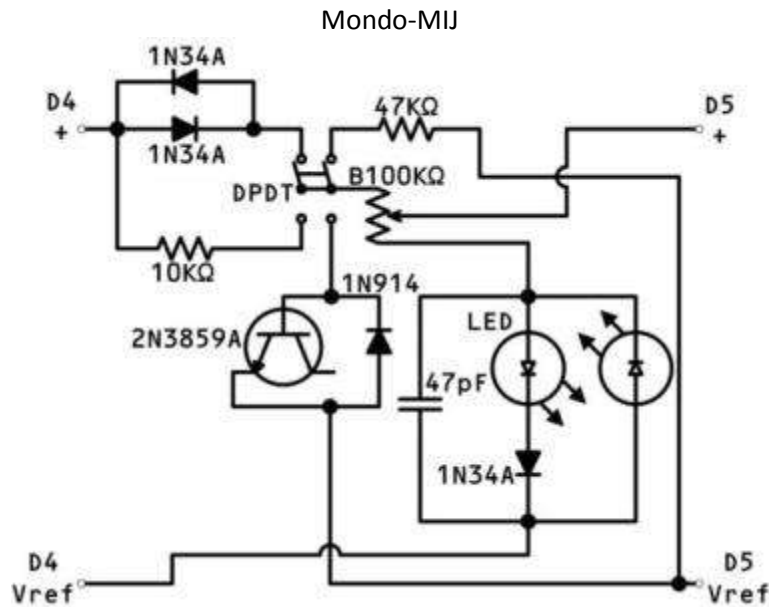

NOTE: The wire between the center (common) lugs of the DPDT and B100KΩ pot *does* connect to both center lugs. Strip the wire about ½” and feed it through both lugs before soldering.

The DPDT toggle switch allows you to switch between crossover distortion and the hard-clipping distortion found in the MIJ-Plus mod. The B100KΩ pot is used to blend the mixture with either more clipping from the LED hard-clipping diodes or the diode pairs controlled by the DPDT. NOTE: Once you’ve built this part of the mod into your “Mondo-MIJ”, you will notice that, other than the diodes controlled by the DPDT, you cannot really turn off any of the diodes in this circuit. This is due to the fact that the DPDT-controlled diodes always have a path between signal and Vref, no matter what the blender pot is set at –and– the fact that the positive (signal) side of D4 and D5 are connected directly outside of this clipping circuit. The effect of the LED/1N34A clipping diodes can be reduced significantly (due to the 100KΩ series resistance presented by the B100KΩ pot), but due to the higher output level of that part of the circuit, their effect cannot be eliminated entirely.

The result of all this blending is a fairly complex distortion with increased headroom, with the ability to “nudge” the signal towards smoother or more aggressive/edgy, depending upon how you set the DPDT and the blender pot. Touch-sensitivity is *vastly* improved, allowing your picking dynamics to determine the amount of distortion the circuit produces. (Meaning: pick softly and it cleans up...dig in hard with the pick and it distorts, akin to similar behavior in tube distortion circuits.)

So now that I'm done with my basic discussion of the theory and design behind Part 3 of the "Mondo-MIJ", let's talk about actually building it.

On all DS-1 variants, B100K Ω pots are used for both the LEVEL and DIST controls. Part 3 of the "Mondo-MIJ" also uses a B100K Ω pot as its blender control. You might think, "Two B100K Ω pots in a pedal already tight on interior space?!" My mind immediately thought "dual B100K Ω pot", which is a good idea...with some caution. Since you will want either the LEVEL or DIST control to operate independently of the Blender control, you will need a dual *concentric* B100K Ω pot. These can be hard to come by, but at the time of this revision, [GuitarFetish](#) has some snazzy [miniature B100K \$\Omega\$ dual concentric pots](#) and [knob sets](#) that work very well for this mod (pictured below on the left.) You might be able to find these pots and knobs elsewhere, but finding them in the B100K Ω variety is tough. If you can locate linear mini dual concentric pots in a larger resistance, you can solder resistors between lugs 1 and 2 plus lugs 2 and 3 (on both pots) to create a 100K pot. (Visit [Joe Davisson's EMH page](#) and click on 'Linear Pot' on the left side for help picking the resistor sizes to make a B100K Ω pot out of your pot.)

On my DS-1, I chose to put the DPDT toggle switch below the TONE control (with the chassis hole approximately centered on the 'O' in TONE.) I replaced the DIST control with the dual concentric B100K Ω pot. I enlarged the hole slightly with a [step drill bit](#) and installed the pot. The GuitarFetish pot come pre-terminated with plastic connectors, which I decided to leave on, as they make for easier assembly/disassembly. To make pin connectors for the wiring and BOSS[®] pot PCB mini-boards, use 22-gauge bus wire. Once you've assembled the connections for both the "Mondo-MIJ" clipping circuit and the DIST control, a piece of electrical tape around the connection will keep them from separating due to vibrations that normal handling and use produce. (If you want to skip dealing with the connectors, just cut off the terminals, strip the wires, tin the ends and solder them up directly.) Below in the center is an exterior shot of my finished "Mondo-MIJ" DS-1.



If you don't want to use (or can't find) a dual concentric B100K Ω pot, there is still hope. Get an [Alpha 12mm B100K \$\Omega\$ pot from Mouser.com](#) (Mouser part number [313-1210F-100K](#)) and a [small knob](#) for it. Leave the LEVEL and DIST pots as-is and find some empty space on the upper-right side of the right vertical face of the pedal (with pedal sitting on its rubber base and knobs on top.) Space will be tight, but you should be able to drill that side and squeeze the pot in there, having the knob protrude out of the right side of the pedal. In the above-right picture, I have marked the alternate location for the Blender pot with a red 'X'.

Once you've done all that, test it, *carefully* box it up and revel in the satisfaction that you have created a great, new sound for your DS-1 –and– just fit 20 pounds of “fertilizer” into a 5-pound bag by fitting all that stuff inside the DS-1 chassis. 😊

To assist you in deciding if the Mondo-MIJ is right for you, the table below has links to sound clips demonstrating the Mondo-MIJ “blender” pot. FYI, these sound clips are supplemental to the other Mondo-MIJ sound clips found on the [Sound Clips](#) page, so please check those out as well.

<u>Mondo-MIJ through a Fender Bassman (4x10)</u>				
<u>1N34A crossover distortion selected on DPDT switch</u>				
Blend Pot @ 7:00	Blend Pot @ 9:30	Blend Pot @ Noon	Blend Pot @ 2:30	Blend Pot @ 5:00
<u>1N914 / NPN hard clippers selected on DPDT switch</u>				
Blend Pot @ 7:00	Blend Pot @ 9:30	Blend Pot @ Noon	Blend Pot @ 2:30	Blend Pot @ 5:00

This mod is an alteration to the low-pass and high-pass filters that feed the TONE control of the DS-1. The intent of this mod is to give the user the option to switch between the stock, scooped-mids tone and a flatter tone shape that will help keep the tone full-sounding at lower DIST settings.

The stock DS-1 TONE control has a low-pass filter with a corner frequency of 234 Hz and a high-pass filter with a corner frequency of 3290 Hz. This produces the classic DS-1 scooped mids tone that allows the harmonics produced by the clipping diodes to be more prominent, giving it a heavily-distorted sound. The PHLAT Mod moves the corner frequencies of both the TONE low-pass and high-pass filters to 1064Hz. This change results in the mid frequencies to jump out more, resulting in a noticeable volume increase, as well as boost in sustain. The resulting distortion is less harmonically rich than the scooped tone, but has a more vintage amp tone that works well with blues and country riffs at lower DIST settings.

To perform the PHLAT Mod, you'll need a DPDT On-On toggle switch, insulated wire, one 68nF film capacitor and one 22nF film capacitor. Once you've obtained those parts, do the following to install it:

- 1) De-solder the 22nF capacitor from C11 and the 100nF capacitor from C12; save these for Step 3.
- 2) Cut and strip two wires and solder them to the common (middle) lugs on DPDT switch.
- 3) Solder the capacitors to the DPDT switch as indicated below:

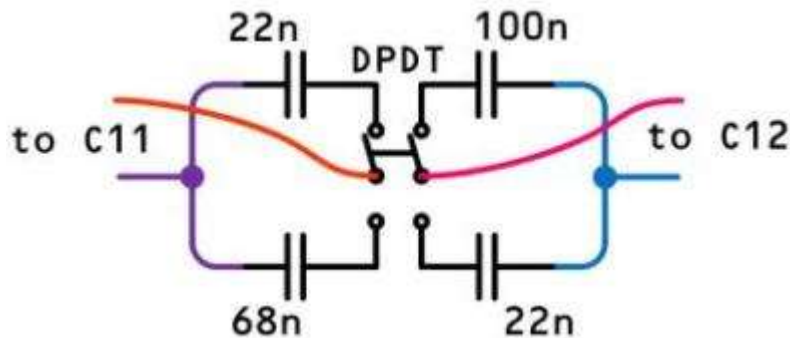

- 4) Cut and strip four wires and solder one each to the leg of the capacitor not soldered to the DPDT switch, then solder the free ends of these wires together as indicated above. Make sure to solder the ends together so that a single-thickness of wire remains to fit through the PCB.
- 5) Drill a hole in the enclosure below the DIST knob and install the DPDT.
- 6) Solder the wires marked 'to C11' above to the holes for the C11 capacitor; do the same for the wires marked 'to C12' above to the holes for the C12 capacitor.

(NOTE: The mods in this section were previously described as the VR-MIJ and VR-MIJ-HG. I've condensed them into one section for the sake of simplicity.)

This mod started with [Jack Orman's "Fat mod for the Boss DS-1" article](#). My initial tests with this mod resulted in an increase in perceived bass and mid frequencies, due to the cut in treble boost from this mod. I wasn't happy with it at first, as it reminded me of a fuzz pedal, which wasn't on my pedal "to do" list at the time.

So after thinking about it more over the next day, I wanted to try combining the Mondo-MIJ mods (minus the clipping network), Jack's "Fat mod" and MOSFET clippers in an attempt to increase the note articulation and cut the fuzz-like qualities of the pedal. I was VERY pleased with the result, which is why I'm presenting it to you here. Please meet the "Vintage Ripper" Mod.

These instructions do not require you to perform any other mods previously to complete the Vintage Ripper Mod. These instructions assume you are starting with a stock post-1994 DS-1.

Vintage Ripper Mod Instructions:

1. Replace C1 with a 0.1µF metal film capacitor.
2. Replace C2 with a 0.47µF metal film capacitor.
3. Replace C5 with a 0.47µF metal film capacitor.
4. Replace C7 with a 250pF ceramic disc capacitor.
5. Replace C8 with a 2.2µF metal film capacitor.
6. Replace C9 with a 0.47µF metal film capacitor.
7. Replace C13 with a 0.1µF metal film capacitor.
8. Replace C14 with a 1µF metal film capacitor.
9. Replace R6 with a 150KΩ metal film resistor.
10. Replace R9 with a 1KΩ metal film resistor.
11. Replace R13 with a 1.2KΩ metal film resistor.
12. Add a 180pF metal film capacitor in parallel to the D4/D5 clipping diodes (solder side).
13. Replace C10 with a 0.027µF metal film capacitor.

14. Remove the D4 and D5 diodes and replace them as directed in the diagram below.

NOTE: Any N-Channel MOSFET can be used here. I used BS170 MOSFETS.

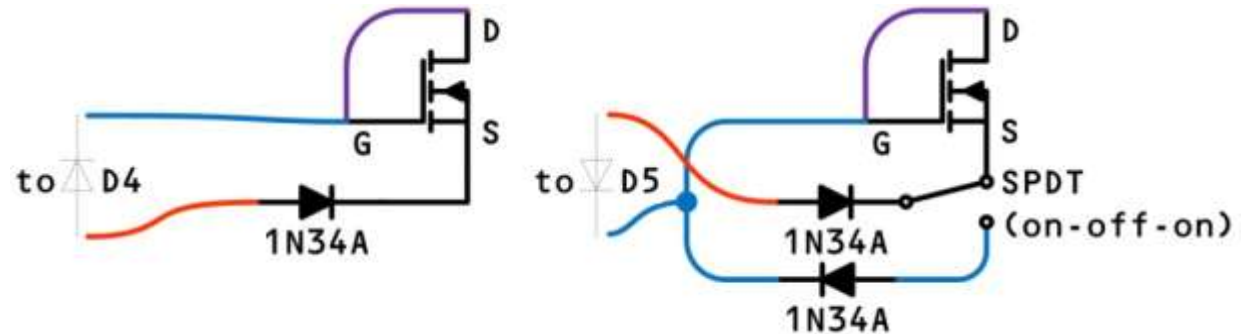

15. Drill a hole below either the DIST or TONE control and mount the SPDT switch in the enclosure.

16. Replace the M5223AL / NJM3404AL in-line dual op amp with a Burr Brown OPA2134PA dual op amp.

The OPA2134PA is a DIP8 package, so you will need to either purchase a SIP8 to DIP8 adapter board or make one yourself. If you wish to buy one, you can buy them from Cimarron Technology: <http://cimarrontechnology.com/index.asp?PageAction=VIEWPROD&ProdID=34>. If you wish to etch and drill your own adapter board, you can use the ready-to-transfer image below.

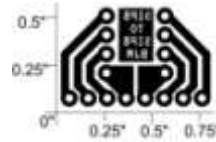

The vertically-aligned holes are for the DIP8 op amp, with Pin 1 being at the upper-left. It is recommended that you install a DIP8 socket in this position. The horizontally-aligned holes are for the pin connectors. You can use 22-gauge tinned bus wire to make these pins by soldering the wire into the hole, bending the wire 90-degrees and clipping to desired length. NOTE: You should install the OPA2134PA op amp *after* you've soldered the DIP8 socket and pins; this will reduce the heat the op amp IC is exposed to.

Once you've got your SIP8 to DIP8 adapter board, de-solder the M5223AL or NJM3404AL op amp and remove it. Install [Mill-Max in-line sockets](#) in place of the removed M5223AL or NJM3404AL. Install the OPA2134PA into the DIP8 socket, then install the entire adapter assembly into the in-line sockets on the main PCB. NOTE: You may need to gently bend the pins on the adapter board one direction or the other to get the necessary clearance to fit everything back into the case.

17. Close up the DS-1 enclosure, plug everything in.

18. At this point, it is critical that you follow these steps:

- A) Rock;
- B) Roll;
- C) Repeat Steps A and B until personal enlightenment is reached. 😊

The short and simple story behind the “Huevos Grandes” Mod is this: I liked the tone of the Vintage Ripper, but wanted to make it less fuzzy and more like a vintage Marshall “Bluesbreaker” sound. I started with the Vintage Ripper and rebiased the Q2 transistor to decrease the input impedance from the Vintage Ripper. The Q2 rebias also put the collector voltage at approximately ½ of supply voltage, which keeps the frequency response of Q2 flatter than the stock DS-1, but doesn’t have the fuzzy/flabby low end caused by the higher input impedance of the Vintage Ripper Q2 rebias. As for the clipping section, I used the diode clipping arrangement found in both the Marshall JMP-1™ tube preamp -and- the Radial Engineering™ Tonebone Classic™. (Both are “tube powered” distortions...well, at least they have tubes in the circuit path while diodes provide the clipping. Just goes to show that “tube distortion” doesn’t always mean tubes are actually providing the distortion/clipping in a given circuit.)

I think you’ll find the Huevos Grandes Mod compares very favorably to other distortion stumps that emulate the Marshall JTM-45 “Bluesbreaker” amp, but the Huevos Grandes Mod costs a fraction of what those pedals cost. ☺ To get a “British Steel”-type distortion on a bridge humbucker-equipped guitar, set the TONE control to around 12:00, the LEVEL control to 2:00 and the DIST control to around 3:00. To get a similar distortion on a bridge single-coil-equipped guitar, set TONE to 11:30, LEVEL to 2:00 and DIST to 3:30. If your bridge single-coil pickups are fairly weak, you can turn the DIST control higher; the Huevos Grandes Mod has enough gain to drive just about any bridge pickup configuration nicely. Also, with the bigger C10 capacitor shunt producing a darker tone, the TONE control is now quite useful when turned either way from Noon.

These instructions do not require you to perform any other mods previously to complete the Huevos Grandes Mod. These instructions assume you are starting with a stock post-1994 DS-1.

Huevos Grandes Mod Instructions:

1. Replace C1 with a 0.1µF metal film capacitor.
2. Replace C2 with a 0.47µF metal film capacitor.
3. Replace C5 with a 0.47µF metal film capacitor.
4. Replace C7 with a 250pF ceramic disc capacitor.
5. Replace C8 with a 2.2µF metal film capacitor.
6. Replace C9 with a 0.47µF metal film capacitor.
7. Replace C10 with a 0.056µF metal film capacitor.
8. Replace C13 with a 0.1µF metal film capacitor.
9. Replace C14 with a 1µF metal film capacitor.
10. Replace R9 with a 220Ω metal film resistor.
11. Replace R13 with a 1.2KΩ metal film resistor.

12. Replace R14 as directed in the diagram below. **NOTE:** I used 1N34A diodes in my build, but you can experiment with different diodes if you want.

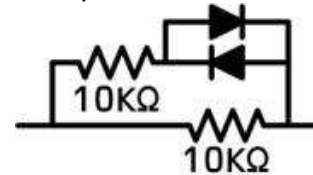

13. Replace R17 with a 15KΩ metal film resistor.
14. Replace D4 with a 0.0039µF (3900pF) metal film capacitor.
15. Replace D5 as directed in the diagram below. **NOTE:** The dotted “diode” in the center is to indicate polarity, not an actual diode; there are only 5 diodes used to in replacement of D5. (FWIW, I used five 1N34A diodes in my build of the Huevos Grandes mod, but feel free to experiment with any common diode type.)

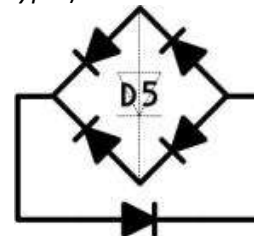

16. On the solder-side of the PC board, solder a 0.0022 μ F (2200pF) metal film capacitor between R18 and R21 as directed below:

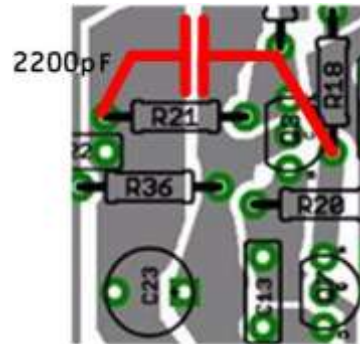

The 2200pF capacitor, in conjunction with series resistor R18, forms a low-pass filter with a corner frequency of 7.24 KHz. This cuts fuzz and even allows the Huevos Grande pedal to sound good WITHOUT using a speaker cab simulator. (Please feel free to test this for yourself if you don't believe me. ☺)

17. Replace the M5223AL / NJM3404AL in-line dual op amp with a Burr Brown OPA2134PA dual op amp.

The OPA2134PA is a DIP8 package, so you will need to either purchase a SIP8 to DIP8 adapter board or make one yourself. If you wish to buy one, you can buy them from Cimarron Technology: <http://cimarrontechnology.com/index.asp?PageAction=VIEWPROD&ProdID=34>. If you wish to etch and drill your own adapter board, you can use the ready-to-transfer image below.

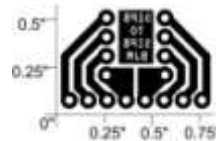

The vertically-aligned holes are for the DIP8 op amp, with Pin 1 being at the upper-left. It is recommended that you install a DIP8 socket in this position. The horizontally-aligned holes are for the pin connectors. You can use 22-gauge tinned bus wire to make these pins by soldering the wire into the hole, bending the wire 90-degrees and clipping to desired length. NOTE: You should install the OPA2134PA op amp *after* you've soldered the DIP8 socket and pins; this will reduce the heat the op amp IC is exposed to.

Once you've got your SIP8 to DIP8 adapter board, de-solder the M5223AL or NJM3404AL op amp and remove it. Install [Mill-Max in-line sockets](#) in place of the removed M5223AL or NJM3404AL. Install the OPA2134PA into the DIP8 socket, then install the entire adapter assembly into the in-line sockets on the main PCB. NOTE: You may need to gently bend the pins on the adapter board one direction or the other to get the necessary clearance to fit everything back into the case.

18. Close up the DS-1 enclosure, plug everything in and enjoy!

SOUND CLIPS

Below are sound clips for all of my DS-1 mods. Please click on a link to download the respective mp3 file and play it on your computer.

NOTE: Please bear in mind that your speakers/headphones can have a large bearing on the quality of sound reproduction on your given system. If you have inefficient, non-flat frequency response speakers/headphones, don't be surprised if the sound clips sound a bit off/thin/whatever. I've done my best to record these sound clips with high-quality and no trickery. All I ask is that you listen to them on quality sound reproduction hardware before you tell me the sound quality is awful. (Thanks. ☺)

With the exception of the Huevos Grandes Mod and Mondo-MIJ Mod, all DS-1 sound clips were recorded with TONE at 10:00, LEVEL at 2:00 and DIST at 2:30. The Huevos Grandes Mod was recorded with TONE at 2:00, Level at 2:00 and DIST at 2:30. The Mondo-MIJ was recorded with TONE at 10:00, LEVEL at 9:30 and DIST at 2:30.

As for the amps, all clips were recorded with the levels set the same, with the exception of the 'Amp only, dirty' clips, as the gain on the respective amplifier was increased to get natural distortion from the amplifier, not the stompbox. All the DS-1 sound clips were recorded with the amp set the same as the 'Amp only, clean' clip for that respective amplifier. The sound clips below are grouped by column according to the amplifier they were recorded with.

<u>Fender Bassman (4x10)</u> Amp only, clean Amp only, dirty	<u>Fender 57 Deluxe (1x12)</u> Amp only, clean Amp only, dirty	<u>Marshall JTM-45 "Bluesbreaker" head (1960TV 4x12)</u> Amp only, clean Amp only, dirty
<u>Huevos Grandes Mod DS-1</u> Clip #1 Clip #2 Clip #3	<u>Huevos Grandes Mod DS-1</u> Clip #1 Clip #2 Clip #3	<u>Huevos Grandes Mod DS-1</u> Clip #1 Clip #2 Clip #3
<u>MIJ-Mod DS-1</u> Clip #1 Clip #2 Clip #3	<u>MIJ-Mod DS-1</u> Clip #1 Clip #2 Clip #3	<u>MIJ-Mod DS-1</u> Clip #1 Clip #2 Clip #3
<u>MIJ-Plus Mod DS-1</u> Clip #1 Clip #2 Clip #3	<u>MIJ-Plus Mod DS-1</u> Clip #1 Clip #2 Clip #3	<u>MIJ-Plus Mod DS-1</u> Clip #1 Clip #2 Clip #3
<u>Mondo-MIJ Mod DS-1</u> Clip #1 Clip #2 Clip #3	<u>Mondo-MIJ Mod DS-1</u> Clip #1 Clip #2 Clip #3	<u>Mondo-MIJ Mod DS-1</u> Clip #1 Clip #2 Clip #3
<u>Mondo-MIJ w/PHLAT Mod DS-1</u> Clip #1 Clip #2 Clip #3	<u>Mondo-MIJ w/PHLAT Mod DS-1</u> Clip #1 Clip #2 Clip #3	<u>Mondo-MIJ w/PHLAT Mod DS-1</u> Clip #1 Clip #2 Clip #3
<u>Original, Made-In-Japan DS-1</u> Clip #1 Clip #2 Clip #3	<u>Original, Made-In-Japan DS-1</u> Clip #1 Clip #2 Clip #3	<u>Original, Made-In-Japan DS-1</u> Clip #1 Clip #2 Clip #3
<u>Vintage Ripper Mod DS-1</u> Clip #1 Clip #2 Clip #3	<u>Vintage Ripper Mod DS-1</u> Clip #1 Clip #2 Clip #3	<u>Vintage Ripper Mod DS-1</u> Clip #1 Clip #2 Clip #3

APPENDIX A: WHERE CAN I FIND B20K POTS?

[Small Bear Electronics](#) has a [G-taper, 20K pot](#) that is designed for Tube Screamer circuits, but you can also make your own B20K pot by taking a B100K pot and adding two 12K5Ω resistors between the lugs as illustrated below:

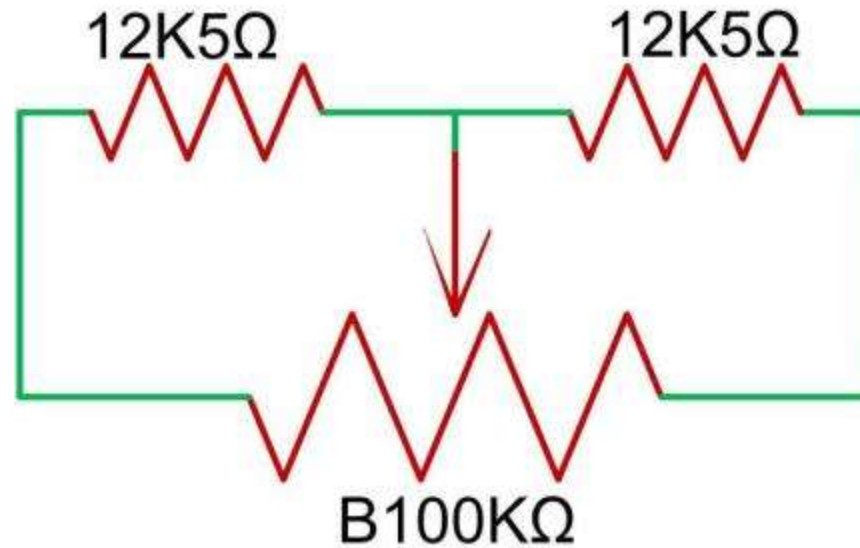

12K5Ω resistors are rather rare in themselves, but 12K4Ω resistors are much more common. If you use 12K4Ω resistors in place of 12K5Ω resistors, you'll end up with 19K9Ω on the pot, which is close enough for our purposes here.

APPENDIX B: HOW DO I MODIFY MY POST-1994 DS-1 TO MATCH THE ORIGINAL DS-1?

First things first, let's set some expectations. Unless you use the TA7136P single op amp (SIP-7) and scour the earth for all of the old transistors/diodes listed in red below, you can't exactly replicate the "vintage" DS-1 Distortion. (You'd also need a PCB layout for the old circuit.) If your intent is to exactly replicate the vintage, Made-In-Japan DS-1, it would certainly be easier (and possibly cheaper) to just save up and buy a MIJ DS-1 on eBay.

It is worth pointing out that many of the transistors and diodes listed in red below are functionally-equivalent to the post-1994 component listed in green next to it. In fact, BOSS[®] often changed the transistors and diodes within the same PCB version of the DS-1. Having the exact component isn't as important as having one that is functionally-equivalent. One should consider that fact before you spend your weekends scavenging 1S2473 diodes from old clock radios in order to build your vintage DS-1 replica.

The intent of this section is not to convert a post-1994 DS-1 to exactly match the pre-1994 circuitry. This section will walk you through the general differences between the circuits and point out likely candidates to modify to make a post-1994 DS-1 more closely match the sound of the vintage DS-1.

Now that's out of the way, if you're like me, believing that you're probably only a few components away from modifying your post-1994 DS-1 to sound like the vintage DS-1, please read on.

From reviewing the schematic for the vintage DS-1, below are the component differences between vintage and post-1994 DS-1 pedals. Values appearing in the vintage DS-1 are in red text, whereas values appearing in the post-1994 DS-1 are in green:

C5 – 0.47μF/50V, 0.068μF	D1 – RD11EB (11V Zener)*, 1N4004	<u>Transistor info for folks building DIY replicas:</u> ¹ 2N5088 transistors may be used in place of 2SC2240 and 2SC732 transistors. You will need to orient the pins differently, as the 2SC2240 and 2SC732 are B-C-E and 2N5088 are C-B-E. ² BC549 or BC559 transistors may be used in place of 2SC2458 transistors. You will need to orient the pins differently, as the 2SC2458 are B-C-E and BC549/BC559 are C-B-E. ³ NTE85 transistors may also be used in place of 2SC945/2SC2458 transistors. The pin-out of NTE85 transistors matches that of 2SC945/2SC2458 transistors, so no adjustment of the pin-out is necessary.
C6 – 150pF, not present	D2 – RD5.1EB (5.1V Zener), 5.6V Zener	
C7 – 250pF, 100pF	D3 – 1S2473, not present	
C8 – 1μF/50V, 0.47μF/50V	D4 – 1S2473, 1N4148	
R12 – 27KΩ, not present	D5 – 1S2473, 1N4148	
R21 – 100KΩ, 10KΩ	D6 – 1S2473, 1N4148	
R34 – 1MΩ, not present	D7 – 1S2473, 1N4148	
R38 – 470Ω, not present	D8 – 1S2473, 1N4148	
R39 – not present, 47KΩ	D9 – 1S2473, not present	
R40 – not present, 1KΩ	Q1 – 2SC732, 2SC2240 ¹	
IC – TA7136P,	Q2 – 2SC732, 2SC2240	
BA728N/M5223AL/NJM3404AL	Q3 – 2SC732, 2SC2240	
	Q4 – 2SC945 ³ , 2SC2458 ²	
	Q5 – 2SC945, 2SC2458	
	Q9 – 2SC945, not present	

So now that we know what components are different between the two, what do those components actually do in the two circuits? OK, let me step through them by functional grouping:

1. D3 and R38 are two components that are connected between battery lug on the DC adapter jack and the Ring terminal on the Input Jack. Going from Input Ring to DC Jack, D3 is connected in series with R38 (with D3 forward current flow going towards the DC Jack); R38 then connects to the battery lug on the DC Jack.

An anonymous associate explained to me that D3 and R38 were used to allow use of the 12VDC ACA-style power supply. You can read more about the function of these components at <http://www.bossarea.com/other/aca.asp>.

And just like that, the mystery was solved and the proverbial scales fell away from my eyes.

Random Rambling: Since we're dealing with potential myths and legends when talking about the vintage DS-1, one might wish to include the D3/R38 hookup in a "vintage DS-1" mod, as some will be quick to point out that those components were in the original DS-1 and are, like the TA7136P op amp IC, "the reason the OLD ones sound better." I'm not in agreement with that sentiment, as my ears tell me that the TA7136P has a slightly compressed sound when compared side-by-side with the M5223AL or NJM3404AL, but it is not the primary driver of the altered sound characteristics anyway...the capacitor differences make the biggest impact on tone by far. But I digress...just use a regulated 9V power adapter with your DS-1 replica and you don't have to worry about D3 and R38.

2. D4 through D8 are silicon signal diodes in the same positions as the 1N4148/1N914-type silicon signal diodes found on the post-1994 DS-1 pedals. Unless you have a rainy Saturday afternoon with nothing better to do, I wouldn't recommend replacing these with 1S2473 diodes (even if you can find some) because the net effect will be negligible.

3. R34, D9 and Q9 are part of the old flip-flop switching circuit design, so unless you're going to revert the entire switching flip-flop circuit from post-1994 to vintage design, ignore these three component differences. If the post-1994 switching circuit flips and flops as you expect, then don't mess with it.

4. *This one could be a bit controversial, as the PCB v.ET-28E BOSS[®] service sheet for the vintage DS-1 has a RD11EB (11V, 0.5W Zener Diode) acting as the reverse-protection diode. BOSS[®] then used 1N4004 diodes in D1 in every PCB version after that PCB v.ET-28E. (My vintage DS-1, PCB v.ET-28F, has a 1N4004 in it.) Since even BOSS[®] couldn't make up their mind which diode was better in the pre-1994 DS-1, I'd recommend sticking with the 1N4004 that BOSS[®] has used in both pre- and post-1994 DS-1 pedals.

As for D2, this Zener diode appears to be part of a "check battery" circuit (along with R35) that will prevent the LED from illuminating when the battery voltage drops below a certain voltage. So changing this Zener diode from a 5.6V Zener to a 5.1V Zener just means your battery will be allowed to drop 0.5 volts lower before the LED stops illuminating, which indicates it's time to change the battery.

Final conclusion on this component change? Minimal, if any, effect on the tone of the circuit. Change 'em if you want, but the effect will be negligible, if noticeable at all.

5. R12 is a biasing resistor. This is not needed on the common dual-op amps that are functional equivalents to the NJM3404AL/M5223AL/JRC4558/OPA2134PA/etc. C6 is a compensation capacitor not needed with the dual op amps in use on the post-1994 DS-1. I'd recommend ignoring these components as candidates for a vintage mod, as they do not apply to the op amps we can use for this pedal. (Dual op amps like those previously mentioned do not have an external compensation loop.)

6. The vintage transistors are functionally-equivalent to the post-1994 parts. I'm not saying you can't replace them if you want, but I really don't think it's worth the effort.

7. R39 and R40 are not in the pre-1994 DS-1. I did an experiment where I removed these resistors and replaced them one-at-a-time with a linear 100K pot. I will now explain my findings from this experiment below.

R39 Result: With a B100KΩ pot wired in for R39 and set to around 47KΩ (stock value), I found it to smooth out the upper mids a bit. When zeroed out, there was a noticeable "yang"-ey characteristic to chords, particular A-chords played in X-0-2-2-0 position. Turning the pot up to 100KΩ smoothed out these mids too much, causing a loss of articulation. It was about half-travel on the pot (just about the 47KΩ BOSS[®] picked for the R39 resistor) that the balance of note articulation versus smoothness seemed to have the best balance. To my ears, BOSS[®] got that resistor value right on the money...47KΩ in R39 sounded best to me.

R40 Result: I did the same procedure with R40 after installing R39 in its original configuration. At anything below 1KΩ, the whole circuit would become inaudible. (Not surprising, because you would have essentially opened a direct connection between +9V and your audio path.) Turning up the resistance above 1KΩ didn't have much audible difference. The biggest difference with R40 came with removing it completely. With R40 removed, there was a drop in the midrange gain, or to put it differently, the clarity and midrange "fatness" dropped off considerably. So once again, I think BOSS[®] made the right call having R40 at 1KΩ with the M5223AL and NJM3404AL chips.

Final Opinion: R39 and R40 are not in the pre-1994 DS-1, but they do smooth and "fatten" the sound of the post-1994 DS-1. Removing these resistors (and jumpering R39) results in a thinner-sounding, somewhat harsh sound with less sustain. R39 and R40 should be left in place on the post-1994 DS-1 as long as the stock M5223AL or NJM3404AL dual op amp is used. If other op amps are used, I would suggest installing a 250KΩ trimpot in place of R39 and a 10KΩ trimpot in place of R40. By adding the trim pots, you could dial in the smoothness/midrange character desired with the replacement dual op amp.

8. OK, time for some more controversy. R21 is 100KΩ on pre-1994 DS-1 PCB version ET-28E and earlier. R21 is 10KΩ on pre-1994 DS-1 PCB version ET-28F and later. My personal, vintage DS-1 has 10KΩ in R21.

So this leaves the modifier with a conundrum. Both 100KΩ and 10KΩ were used in R21 on vintage, MIJ DS-1 pedals. From my research, it appears that the majority of vintage DS-1 pedals were shipped with 10KΩ in R21, which is why I recommend not changing R21 from the 10KΩ value held in common with the post-1994 DS-1.

So now that we've eliminated most of the differences as potential mod components, what does that leave us? Why, that gives us the "[MIJ-Mod](#)."